



# HOTEL AM BADERSEE

ZUGSPITZDORF GRAINAU



## INSPIRING

THE CONVENTION MAGAZINE - FACTS FOR YOUR SUCCESS AT BADERSEE

## FOYER

Dear Guests,  
Dear Promoters, Trainers, and Organisers,

This conference magazine is the fact sheet for everything you need to know to do with your event at our beautiful hotel. Printed here you will see what is possible at the Hotel am Badersee and what you can expect. Our MICE Department will be happy to assist you in the implementation of your event.

This magazine gives you an overview of the pure facts concerning rooms, areas, capacities, technology and possibilities, if you are planning a seminar, a conference, or similar type of event. For more extensive picture material, convincing arguments and emotions, we recommend to you our brochure, our homepage, the Facebook fansite and our Youtube channel including promotional video.

You and your conference guests will certainly be delighted with a wide range of organisation possibilities of your event in our hotel. Plan your event according to your wishes with the help of our MICE teams: Standard seating or modern events, open-air conferences with a “beer garden atmosphere” or a creative outdoor event in our original “Zugspitze cable car cabin”.

In our natural-based creative conference rooms, you and your conference guests will feel like you are taking a walk in the woods. Our coworking office “The Lakeview Office” can also be booked exclusively for work sessions or board meetings. You will feel at home!

Needless to say, a framework programme for your event should not be missing – for this purpose, we work together with experienced agencies which can make almost everything possible. Our hotel also has much to offer, just ask our MICE team.

As a hotel certified by the VDR, the highest quality is part of our philosophy. We also pay particular attention to the environment: In addition to an efficient use of energy and water, we place great importance to short delivery routes as well as regional products for our food. Support us in protecting our environment in the future.

The best thing to do is to come and visit us in person, to find out for yourself that the Badersee is always the right decision. We will be happy to advise you, and will organise and support your event until the last guest has left.

With Best Regards  
from the foothills of the Zugspitze



## INHALTSVERZEICHNIS

Hotel am Badersee in numbers	4
Reaching the Badersee	5
Overview of the rooms according to technical features	6
Overview of the rooms according to capacities	7
Graphic overview of the rooms	8
Creative meeting spaces	14
Lakeview Office – Coworking@Badersee	15
Modern and dynamic event designs	16
Open-air meetings	18
Suggestions for the wow effect	19
Conference technology	20
Coffee breaks and beverages	20
Conference packages	21
Social Media	23
Environmental responsibility	24
Cancellation terms	25
General terms & conditions	26

# HOTEL AM BADERSEE IN NUMBERS

## General

Class:	4-star hotel
100 free outdoor parking spaces 50 underground parking spaces (against charge)	
Opening times:	Open all year
The entire hotel is smoke-free as stipulated by Bavarian law	
WiFi:	Available free of charge throughout the hotel

## Guest Rooms

135 guest rooms, some with a view of Zugspitze and Lake Badersee, some with a view of Hoher Ziegspitz, of which

- 80 Landhaus Komfort guest rooms in two different designs
- 2 Landhaus Komfort guest rooms as two-room family rooms
- 2 Landhaus Komfort guest rooms as single rooms with wheelchair access
- 30 Seehaus Komfort guest rooms with a view of Kramer Mountain
- 20 Seehaus Superior guest rooms with a view of Zugspitze and Lake Badersee
- 1 Maisonette Suiten with a view of Zugspitze and Lake Badersee

All guest rooms are furnished according to 4-star standards. Every guest room has an in-room safe and a TV that you can connect your laptop to. At Hotel am Badersee we care about sustainability, which is why



we chose in our classification not to have mini bars but instead to place vending machines at various locations throughout the hotel.



## Food & Drink

**"Werdenfels"** restaurant with winter garden and terrace. Buffet and à la carte with a view of Zugspitze and Lake Badersee. Lunch and dinner takes place here unless otherwise arranged for your meeting or conference. Seats 160.

**"Seestüberl"** an authentic basement pub with vaulted ceilings and a large fireplace. Open for events by appointment. Seats 80.

**"Talstation"** an evening bar with fireplace lounge and big screen TV featuring Sky Sports programs. Seats 80.

## Conference Rooms

22 rooms	of which 18 in the atrium
Divided	16 conference rooms, of which 4 in the Seehaus and 6 group rooms
Undivided	14 conference rooms, of which 2 in the Seehaus and 6 group rooms
Total area of the rooms:	1.240 sqm (13,130 sqft)
Largest room:	210 sqm (2,260 sqft)
Exhibition space:	up to 300 sqm (3,230 sqft) in the atrium
Outdoor space for events:	Many options

## GETTING HERE

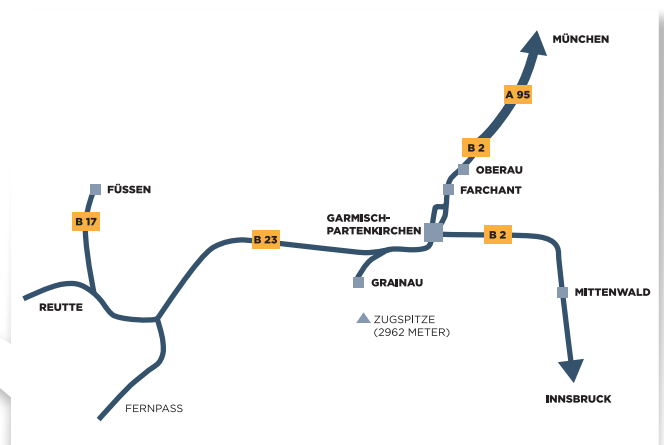

### Coming from

Munich International Airport  
 Innsbruck Airport  
 Garmisch-Partenkirchen Train Station  
 Zugspitzbahn Station in Grainau

Continue by train or rental car / 132 km (82 mi)  
 Continue by train or rental car / 65 km (40 mi)  
 Continue by taxi / 8 km (5 mi)  
 0.8 km (0.5 miles) / 10-minute walk

### By car

Autobahn A95 from Munich 22 km (14 mi) / 20 minutes  
 Autobahn A7 from Ulm via Reutte (Austria) 55 km (34 mi) / 45 minutes  
 Autobahn A12 from Innsbruck (Austria) 57 km (35 mi) / 50 minutes

## OVERVIEW OF THE ROOMS BY TECHNICAL FEATURES

Conference Room	Type	Combinable	Size	Width	Length	Height	Location	Access	Technique
Badersee	T		210sqm	15m	15m	3.0m	SH	TR	B
Pfaffenwinkel	T		140sqm	17.6m	8.0m	2.8m	SH	TR	-
Friederspitz	T(VDR)		119sqm	11.9m	10m	2.95m	UG	GR	B
Zugspitz	T(VDR)		114sqm	11.9m	9.6m	3.0m	ZG	BK	B
Badersee I	T	4	105sqm	15m	7.5m	3.0m	SH	TR	-
Badersee II	T	4	105sqm	15m	7.5m	3.0m	SH	TR	B
Kreuzeck/Partnach	T(VDR)		82sqm	11.2m	7.3m	2.9m	UG	GR	B+MO
Alpspitz	K(VDR)		77sqm	11m	7.0m	3.0m	ZG	BK	B
Pfaffenwinkel I	T	3	75sqm	9.4m	8.0m	2.8m	SH	TR	-
Kramer	T		71sqm	11.2m	6.4m	2.4m	OG	BK	B
Wetterstein	T(VDR)		79sqm	11.3m	7.0m	3.0m	ZG	BK	B
Pfaffenwinkel II	T	3	65sqm	8.2m	8.0m	2.8m	SH	-	-
Dreiterspitz	T(VDR)		66sqm	9.5m	7.0m	3.0m	ZG	BK	B
Riffelspitz/Höllental	T(VDR)		65sqm	9.4m	6.9m	3.0m	UG	GR	B+MO
Großer Waxenstein	T		52sqm	10.9m	4.8m	2.4m	OG	BK	B
Kreuzeck	T(VDR)	1	43sqm	5.8m	7.3m	2.9m	UG	GR	B
Reintal	T(VDR)		41sqm	6.9m	6m	3.0m	ZG	BK	B
Partnach	T(VDR)	1	39sqm	5.4m	7.3m	2.9m	UG	GR	MO
Frillensee	K(VDR)		36sqm	6.5m	5.5m	3.0m	ZG	BK	B
Pflegensee	T(VDR)		36sqm	6.5m	5.5m	3.0m	ZG	BK	B
Riffelspitz	G	2	32sqm	4.2m	7.5m	3.0m	UG	GR	MO
Höllental	G	2	32sqm	5.8m	7.5m	3.0m	UG	GR	B
Loonie	G		23sqm	6.2m	3.8m	2.5m	EG	-	MO
Kleiner Waxenstein	G		18sqm	4.7m	4.0m	2.4m	OG	BK	MO
Rosensee	G		18sqm	5.1m	3.6m	2.4m	OG	BK	MO
Schmölzersee	G		14sqm	4.8m	2.9m	2.4m	OG	-	MO

### LOCATION

VDR = Certified by Verband deutsches Reisemanagement (The German Business Travel Association).

UG = Conference Atrium basement.  
Relates to the regular ground floor.

All coffee breaks are taken in this area.

EG = Conference Atrium. Same floor as hotel lobby.

ZG = Conference Atrium. Relates to the first middle floor.  
The MICE office is located in this area.

OG = Conference Atrium. Relates to the first floor of the Atrium (second conference area).

SH = Lake house

### TYPE

T = Conference room

G = Group break-out room

K = Creative conference room

### Access

TR = Terrace

BK = Balcony with staircase  
leading down

GR = direct access to the garden

### TECHNIQUE

B = Data projector integrated

MO = Monitor

## OUR CONFERENCE ROOMS ACCORDING TO CAPACITIES

Conference Room	Type	U-Shape	Parlament	Theatre style	Block	Banquet
Badersee	T	40	130	200	-	120
Pfaffenwinkel	T	22	60	90	o. r.*	70
Friederspitz	T(VDR)	30	50	80	48	-
Zugspitz	T(VDR)	28	60	93	-	-
Badersee I	T	22	60	87	30	70
Badersee II	T	22	60	87	30	70
Kreuzeck/Partnach	T(VDR)	24	24	60	28	-
Kreativraum Alpispitz	K(VDR)	22	24	50	24	-
Pfaffenwinkel I	T	18	30	40	26	36
Kramer	T	20	20	35	26	-
Wetterstein	T(VDR)	20	24	50	24	-
Pfaffenwinkel II	T	18	30	40	26	36
Dreiterspitz	T(VDR)	16	24	35	20	-
Riffelspitz/Höllental	T(VDR)	20	20	40	22	-
Großer Waxenstein	T	14	16	20	16	-
Kreuzeck	T(VDR)	14	16	o. r.*	20	-
Reintal	T(VDR)	12	16	o. r.*	20	-
Partnach	T(VDR)	10	-	o. r.*	12	-
Kreativraum Frillensee	K(VDR)	8	-	-	12	-
Pflegensee	T(VDR)	8	-	-	12	-
Riffelspitz	G	10	-	o. r.*	12	-
Höllental	G	10	-	o. r.*	12	-
Loonie	G	-	-	-	12	-
Kleiner Waxenstein	G	-	-	-	8	-
Rosensee	G	-	-	-	8	-
Schmölzersee	G	-	-	-	6	-

o. r.\* = on request

All stated numbers of people refer to standard seating. In the end, the MICE Department will clarify the nature of your event with you and what space requirements result from this.

The following room sketches show examples of seating.  
The room capacities are determined by the above lists.

## GRAPHIC OVERVIEW OF THE ROOMS

### Badersee

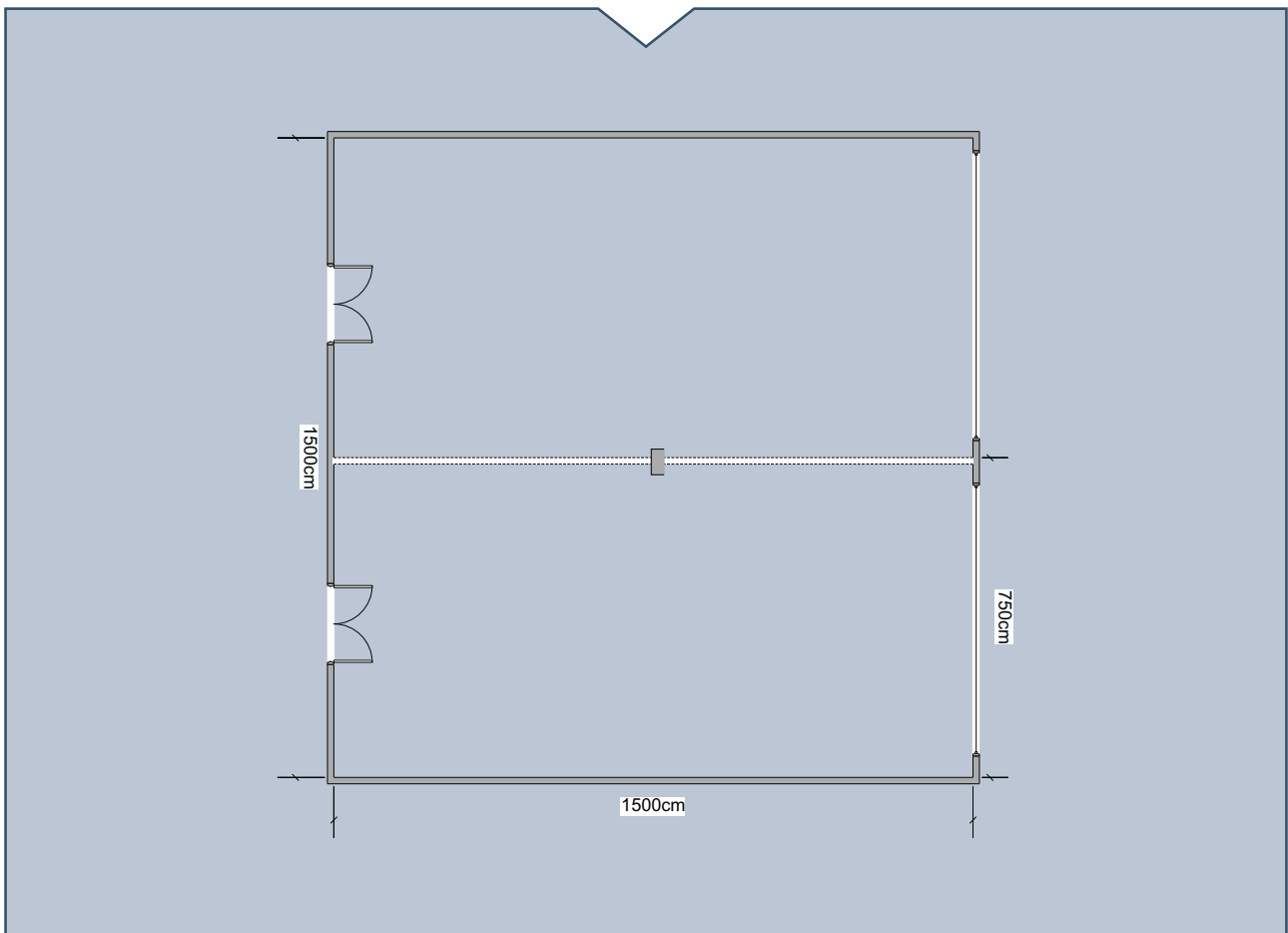

The room is located in the basement of the lakeside hotel and possesses a direct connection to the lake via a broad terrace front. The wood panelling makes it suitable for ceremonial occasions as well as for use as a conference room.

Audio and video technology and an air-conditioning system have been incorporated. If required, the room can be divided by a soundproof wall, with both rooms retaining access to the lake. The floor covering consists of parquet-type tiles.





## Zugspitz

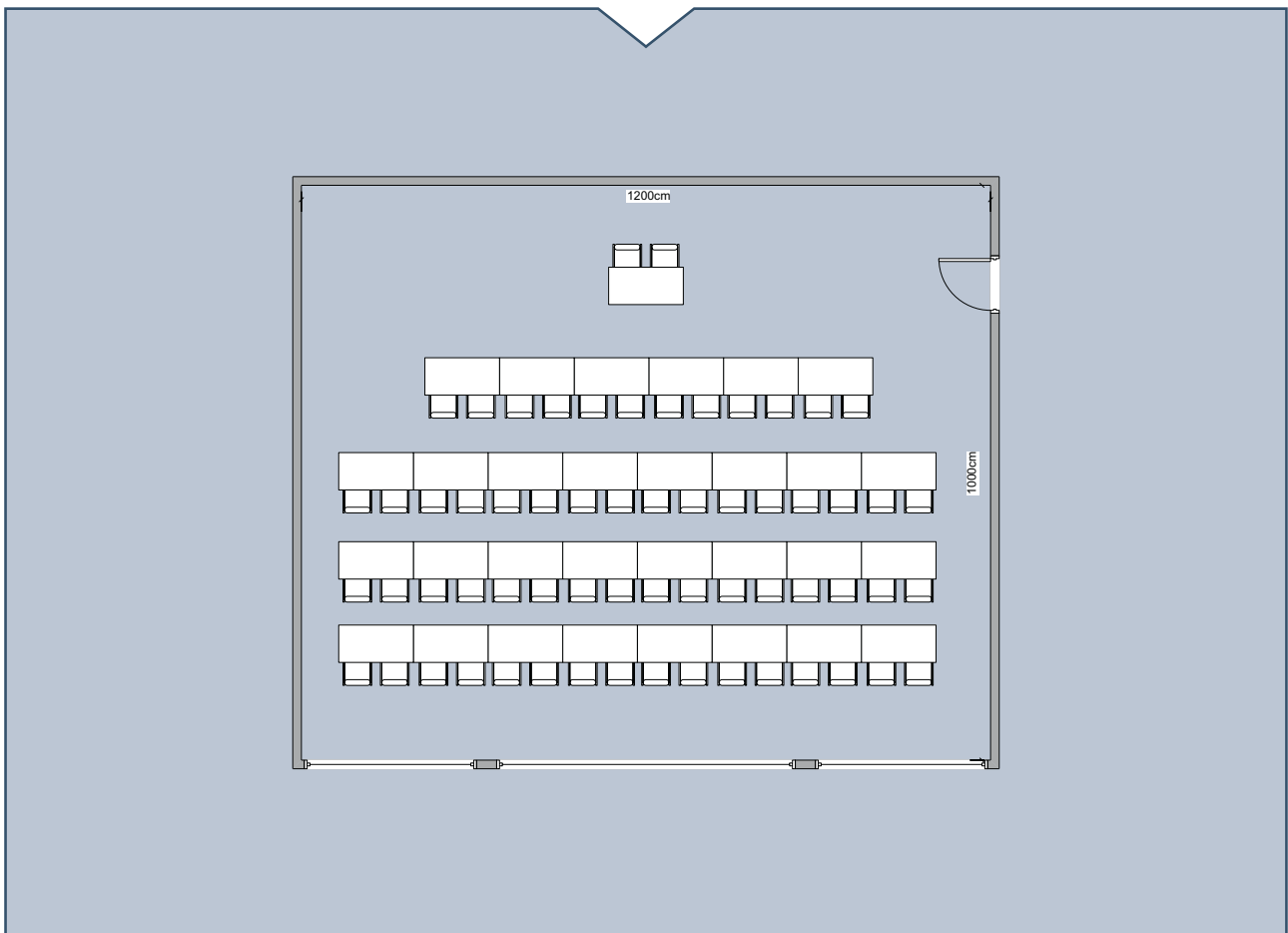

The room is located on the 1st floor of the conference atrium and can be conveniently reached from the other levels and from the hotel lobby.

A complete window wall and a side window provide plenty of daylight. In addition, it is possible to go through a door onto an external balcony and from there directly downstairs.



## Pfaffenwinkel

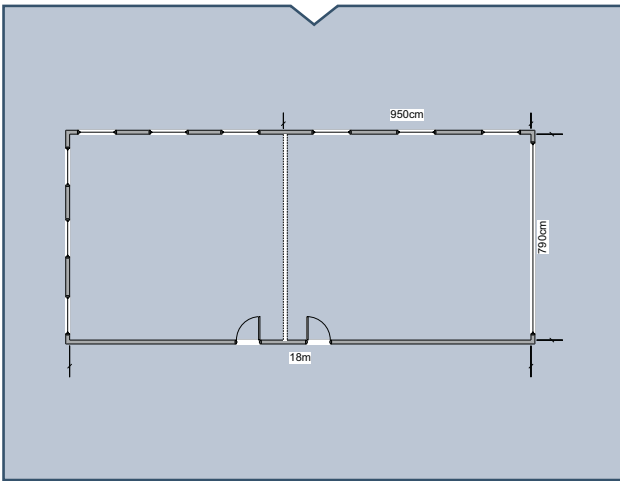

Location: In the lake-house on restaurant level  
with access to the terrace  
Floor: Carpet

## Wetterstein

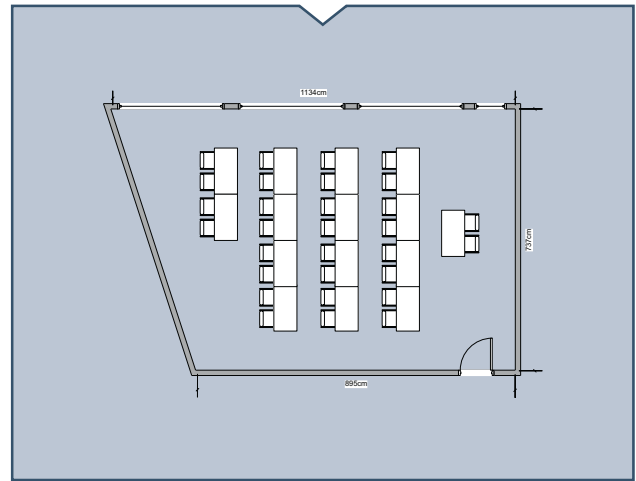

Location: On the mezzanine  
next to the MICE office  
Floor: Carpet

## Alpspitz (Creative conference room)

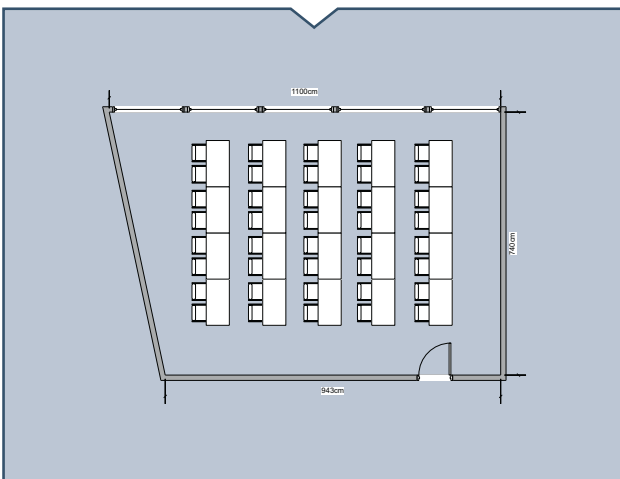

Location: Mezzanine in the conference atrium  
Floor: Carpet

## Dreitorspitz

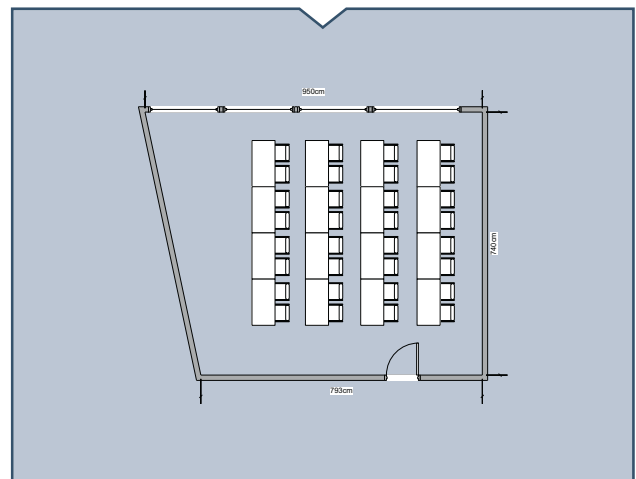

Location: On the mezzanine  
Floor: Carpet

## Kramer

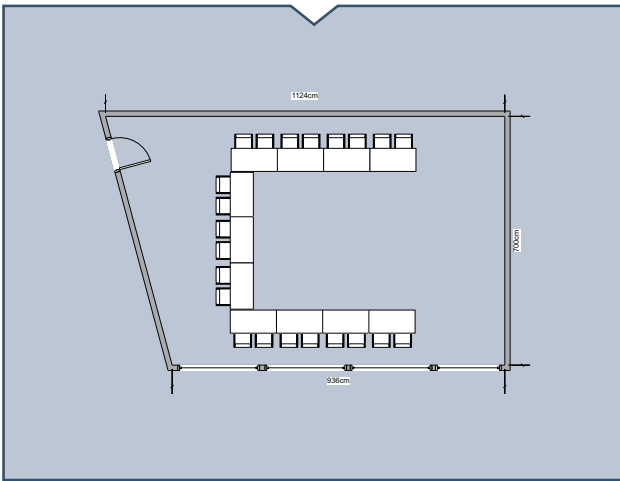

Location: Top floor in the conference atrium  
 Floor: Carpet

## Friederspitz

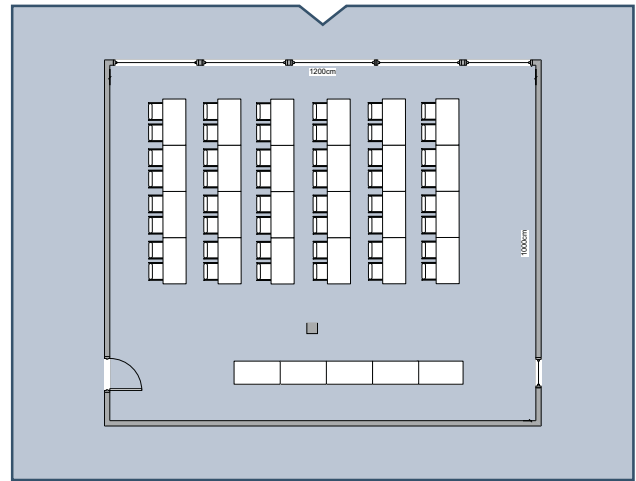

Location: Basement (like ground floor)  
 in the conference atrium.  
 Level of the creative/break area.  
 Floor: Carpet

## Kreuzeck / Partnach

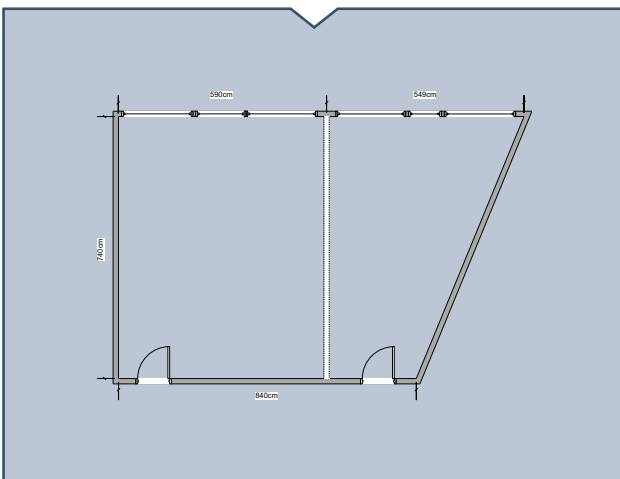

Location: In the basement next to the  
 creative/break area  
 Floor: Carpet  
 Partition: If required, a conference room and a  
 group room can be created

## Riffelspitz / Höllental

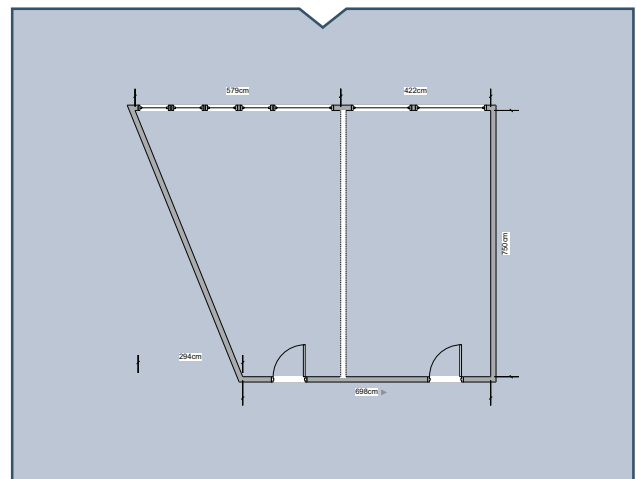

Location: In the basement, close to creative/  
 break area  
 Floor: Carpet  
 Partition: If required, a conference room and  
 a group room can be created

## Großer Waxenstein

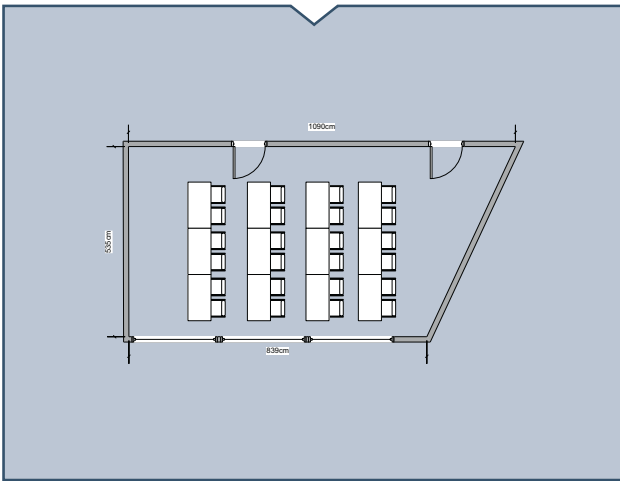

Location: On the top floor  
Floor: Carpet

## Kleiner Waxenstein

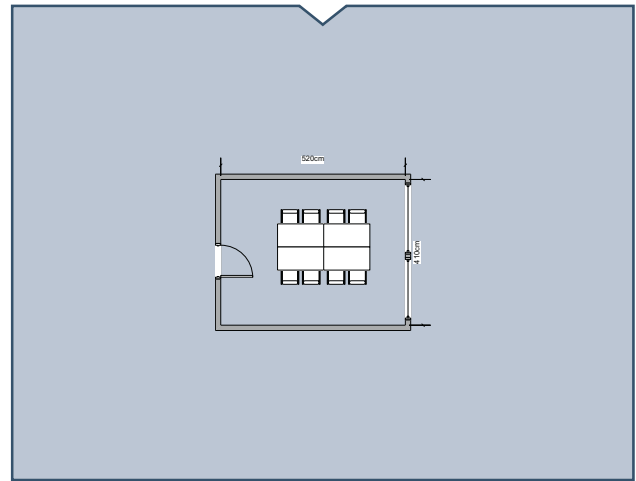

Location: On the top floor  
Floor: Carpet  
Suitability: Group room or small meeting room

## Rosensee / Schmölzersee

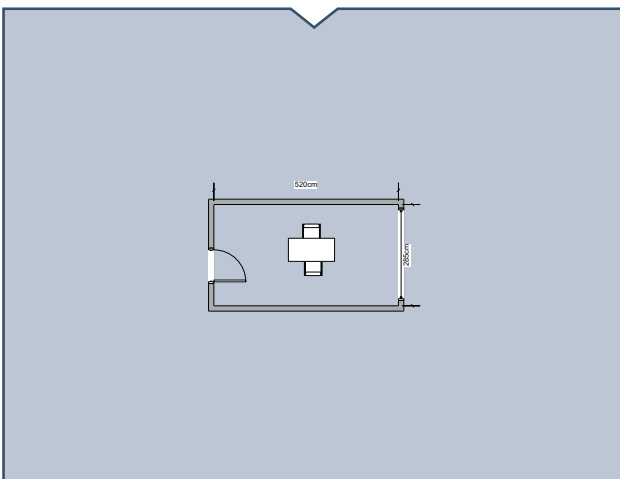

Location: On the top floor  
Floor: Carpet  
Suitability: Group rooms or small meeting rooms

## Reintal

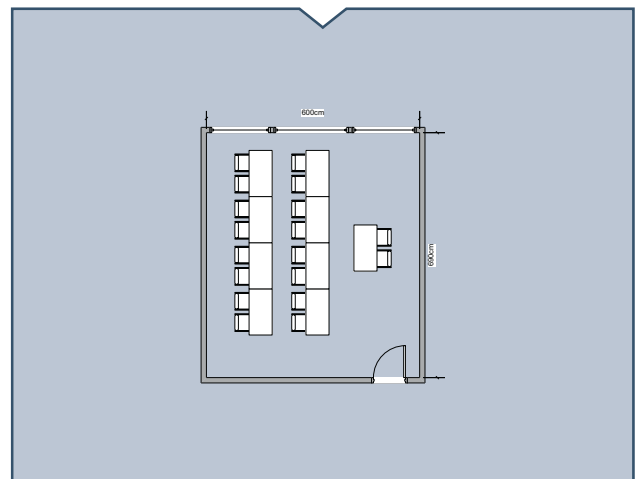

Location: On the mezzanine next to the MICE office  
Floor: Carpet

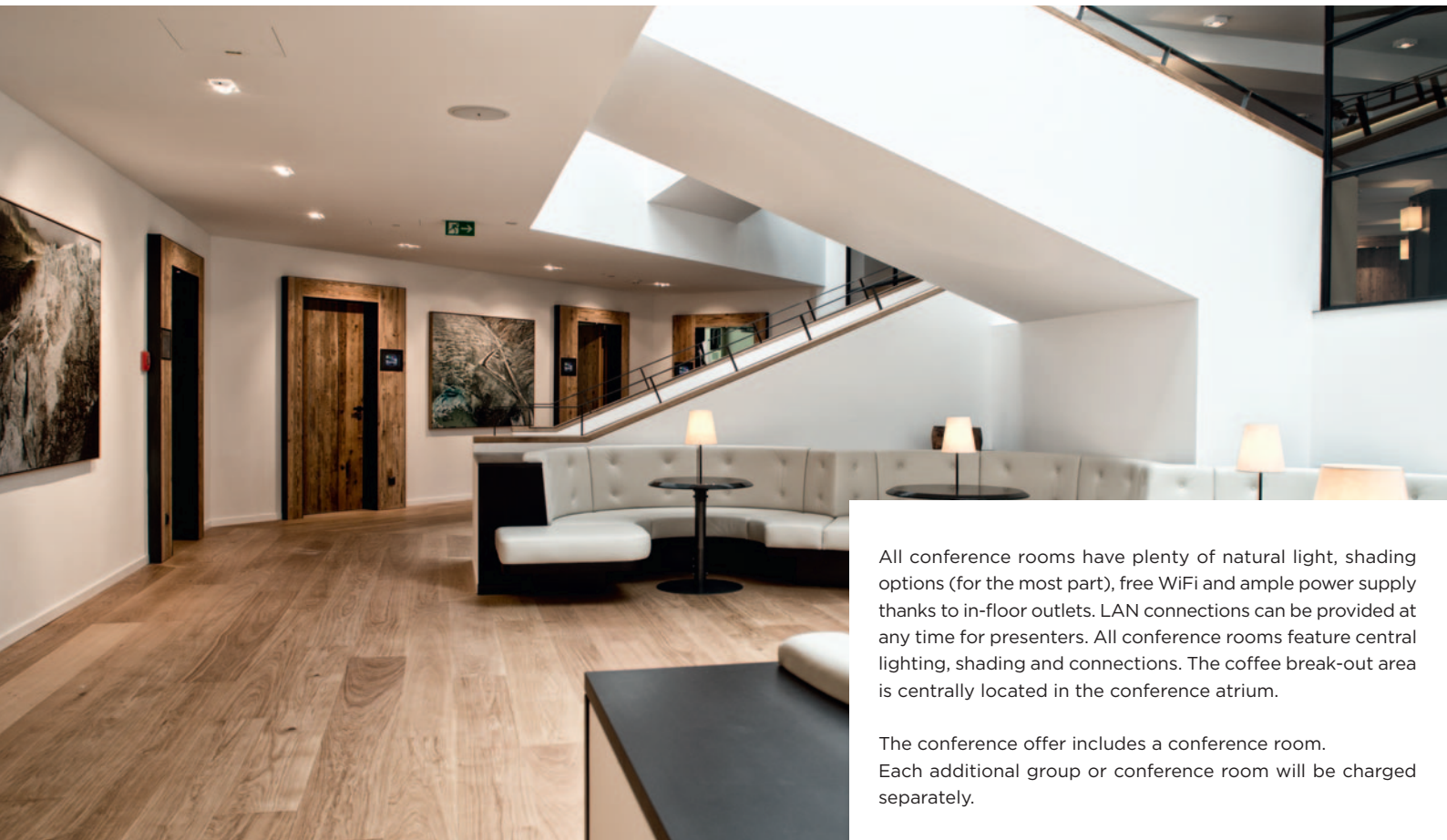

All conference rooms have plenty of natural light, shading options (for the most part), free WiFi and ample power supply thanks to in-floor outlets. LAN connections can be provided at any time for presenters. All conference rooms feature central lighting, shading and connections. The coffee break-out area is centrally located in the conference atrium.

The conference offer includes a conference room. Each additional group or conference room will be charged separately.

Room rental agreements govern the use of rooms and facilities not included in the respective package. The MICE office is happy to make you an offer.

**Frillensee (Creative conference room) / Pfliegersee      Loonie**

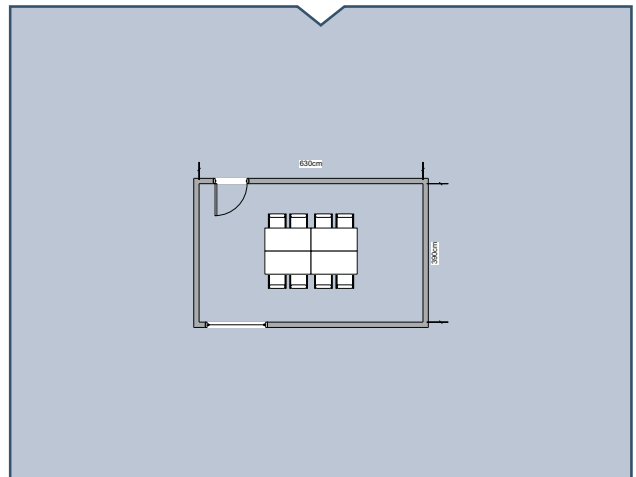
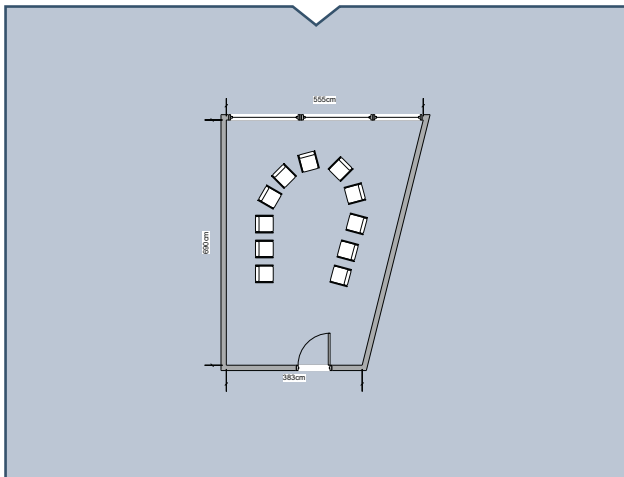

Location: On the mezzanine, close to MICE office  
 Floor: Carpet  
 Suitability: Group rooms or meeting rooms

Location: Ground floor on lobby level  
 Floor: Carpet  
 Suitability: Group room

## OUR CREATIVE CONFERENCE ROOMS

Imagine you are on a hiking tour in the mountains with your friends and opt for having a picnic. At the same time, you discuss new projects and ideas and get inspired by the magnificent nature.

You will feel this way in our creative conference rooms, as we included the magnificent nature surrounding us in them. This unique and natural surrounding is perfect for working, designing interactively and developing ideas.

### Alpspitz

---



#### Creative set-up possibilities

Fatboys with side tables for max. 24 persons  
Wooden benches with seat cushions  
for max. 36 persons  
More ideas on different set-ups with a maximum  
number of people can be found on our website.

#### Creative set-up possibilities

Wooden benches for max. 16 persons  
Fatboys with side tables for max. 8 persons  
High tables for max. 16 persons  
More ideas on different set-ups  
can be found on our website.



## LAKEVIEW OFFICE - COWORKING@BADERSEE

You are looking for a special room for a work session or an Executive Board meeting? How about our new coworking office?

The fully equipped coworking office is located on the 2nd floor of the Seehaus and consists of 11-13 flexdesks distributed over 2 floors, including 6 table seats, 3 bar seats as well as 4 lounge seats. Wi-Fi, a printer with a scan and copy function, a TV-screen for presentations as well as coffee, tea and mineral water are available free of charge.

The coworking office is ideal for an intensive work session during which the participants develop ideas and projects on their laptop - individually or in close dialogue with each other. Eventually, these ideas and projects are put together and presented in a plenary session.

The unique atmosphere of the Lakeview Office creates the perfect framework for an Executive Board meeting for up to 6 persons.

You can discuss all major issues at a long table in a relaxed and cosy atmosphere. During the meeting, a presentation can be viewed on a large plasma screen upon request. You will feel completely at ease with comfortable chairs, coffee/tea and mineral water during the meeting. If desired, we can also provide small snacks.

Occasionally, fresh air and inspiring views of the Zugspitze and the Badersee can be enjoyed from the balcony of the Lakeview Office.



## DOING EVENTS DIFFERENTLY MODERN & DYNAMIC

In addition to the common event set-ups – parliamentary, rows of chairs, block and U-shape – we are happy to implement current and modern event methods upon request.

Are you familiar with “Fishbowl”, “World Café”, “Design Thinking” or “Walk & Talk”? All these event formats foster the creativity of the participants as well as their active participation in the event. Our MICE team will be happy to advise you.

### World Café

---

During a World Café, small groups of people sit at small tables and have conversations with each other in a casual and trusting atmosphere like in a coffee house.

Ideal group size: 20-30 persons,  
more than 30 persons

Duration: 2 hours

Materials: Several tables, writeable  
table covers, pens, a bell or gong

#### Advantages:

- Promotes an active, attentive listener
- Opens up new perspectives
- Opens up innovative possibilities for action



### Barcamp

---

A Barcamp describes an open meeting with open workshops the content and sequence of which can

be determined by the participants at the beginning of the meeting and are shaped in the course of the event. Barcamps facilitate a substantive exchange and discussions; however, they can partially show concrete results at the end of the event.

Ideal group size: 50-150 persons

Duration: 1-2 days

Meeting room for plenary sessions plus several  
Break-out rooms

Materials: Equipment for moderation, several  
flipcharts, pinboards, pens

#### Advantages:

- Topics are not predefined, they arise during the discussions
- Anyone can participate and introduce topics
- Very interactive groups with a high exchange of experience
- New perspectives and creative ideas
- Many small sessions on several topics at the same time.



### Fishbowl

---

Fishbowl is a simple but dynamic alternative to a panel discussion. Fishbowl makes an event more lively and spontaneous. The Fishbowl consists of an inner circle of chairs set up and one or several outer circles. The discussion takes place in the inner circle.

Ideal group size: 20-30 persons

Duration: 1-2 hours



**Advantages:**

- Dynamic, interactive discussion group
- Manageable, small discussion group
- Listeners in the outer circle can take part in the discussion and sit in the inner circle at any time
- Free development of the discussion; new topics can arise during the discussion



**Design Thinking**

---

Design Thinking is a creative and collaborative problem-solving method from a user’s perspective. The aim is to find solutions that are convincing from the user’s point of view. Design Thinking keeps an eye on the end user and consists of five phases which can be repeated at any time in order to achieve the best possible result.

Ideal group size: 20-30 persons

Duration: 2-3 days, depending on the group size and the topics

Materials: Equipment for moderation, several flipcharts, pinboards, post-its, pens

**Advantages:**

- Renewal, reorientation or improvement of products, services and trade goods
- Direct exchange with customers. The customer comes first
- Creative problem solution, teamwork and visualisation of solution approaches



**Walk & Talk**

---

Exercise sets your mind and soul free and doing it in the fresh air is even healthier. For Walk & Talk, new trains of thought are set free during a walk in the woods. Researchers at Stanford University confirm the creative power of taking a walk.

Ideal group size: max. 10 persons per walk

Duration: 30-60 minutes

Materials: Trainers or solid shoes, depending on the path surface

**Advantages:**

- Promotes creativity
- Refreshment for the body and mind
- New perspectives and approaches





## OPEN-AIR MEETINGS

Anyone who attends a meeting or an event in the Hotel am Badersee should take advantage of the opportunity of enjoying the surrounding nature – not just from the window of the conference room.

That is why we offer our conference guests the possibility to organise an outdoor event, if the weather permits.

The best location for this is the large patio in front of the conference atrium. In addition to the available lounge seats for group work sessions, the patio can be transformed to host a smaller conference for up to 20 persons. The U-shape, rows of chairs or parliamentary set-ups are particularly suitable.

Modern event formats such as World Café or Fish-bowl are ideal solutions for outdoor events.

Upon request, we can organise a parliamentary event “Bavarian style” with comfortable beer tables for up to 32 persons on the terrace of our restaurant “Seestüberl”.

A special outdoor highlight is our original „Zugspitze cable car cabin“ for up to 8 persons. In this cabin, the creative and interactive exchange of ideas is particularly enjoyable. The windows can be used as a working surface with a fantastic view of the Zugspitze. Who can claim to have done brainstorming in a cable car cabin?



## OPEN-AIR MEETINGS NATURE RESPONSE GROUP PRACTICE WITH



NATURESPONSE® combines group practice out in the nature to boost your team spirit and company growth with a new way of thinking and individual perception. The nature lets humans develop a feeling of awareness and presence, experience belonging to a group more easily and intensively, and set common objectives. You can plan NATURESPONSE® group practice as an external activity or integrate it in your team work during the event. Exercises are suited for groups up to 50

participants, they are easy to conduct and are free of charge. The Hotel am Badersee provides you with a route map that also includes a detailed description of every exercise. Those can be done on your own with your group mates. Two separate NATURESPONSE® rounds guide you around the Badersee. The only requirements for your team is steady footwear and a weather appropriate outfit.



## TEAM INCENTIVES FOR A WOW EFFECT

Let your meeting become an unforgettable experience - with our special 'wow' incentives. Be it winter or summer season, our region offers outstanding opportunities for teambuilding events that you can easily integrate in your team activities. Here just a few options:

**Winter:** riding a giant ski, scoopjet rally, visit to the Zugspitze Iglu Village, FIS Ski World Championship, snowshoeing to an alpine chalet and many more.

**Summer:** giant stand-up paddle, archery contest, GPS geocaching, high ropes course, Shinrin Yoku, visit to the ski jumping hill, mountainbike or trekking tour, mountaineering for beginners and many more.

**All year round:** trekking the Partnach Gorge, visit to the Linderhof Palace or Ettal Monastery, inhouse: readings with book authors, Criminal Dinner, bowling, cocktail making course, live music, laser show and many more.



## EQUIPMENT

The standard equipment included in the conference package comprises the following setup (already integrated in some rooms): projector screen, 1 projector, 1 pinboard, 1 flipchart, 1 presentation case, notepads and pens.

We can also offer you additional equipment against surcharge:

- Flipchart
- Pinboard
- Presentation case
- Laser pointer
- Visualizer
- Laptop with Microsoft Office
- Portable printer
- Conference phone
- Digital camera
- 117 cm (46 in) flatscreen TV
- Portable projector
- Sound system with microphones
- Lectern
- High-quality writing pads
- Technical assistance

We work with local partners should you need additional equipment.

Our MICE office has a large supply of cable connectors for your convenience.

## BREAKS AND BEVERAGES

We serve you delicious specialties from our kitchen and our own patisserie during breaks.

### Morning

Healthy fruit with a selection of sweet and savory items.

### Afternoon

Delicious cakes and tortes from our own patisserie.

At every coffee break we serve fresh coffees from the coffee machine and a variety of teas in the break area on the lower ground floor.

### Special breaks

We can complete your breaks with the following delicacies against surcharge.

Coffee break incl. snacks

Additional coffee/tea

Open-faced sandwich (half-roll)

Buttered pretzel small / big

Pretzel with Obatzda spread

1 pair of Weißwurst sausages with mustard and a pretzel

Fruit basket

Mini pizza

Tomato-mozzarella sticks

Cheese-salami squares

Canapés

Goulash soup with bread

### Beverages during the meeting/conference:

The coolers on the tables are filled with bottled water, various juices and Coca Cola (depending on the conference package you booked).

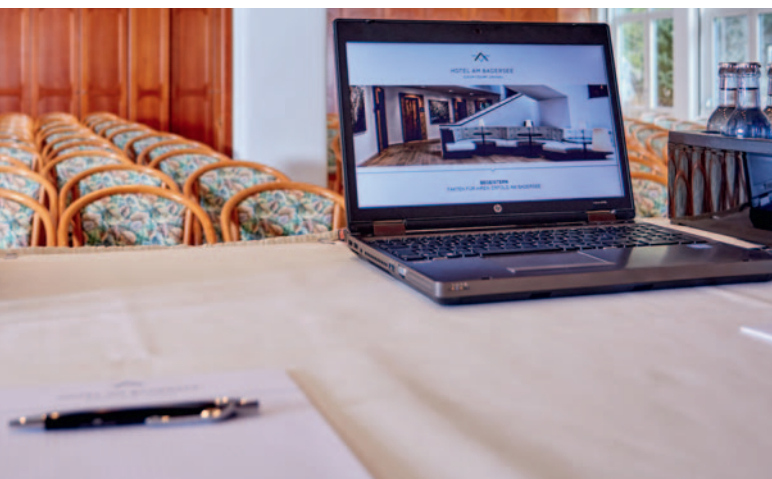

## CONFERENCE PACKAGES FOR TEN OR MORE PARTICIPANTS

For all meeting occasions we are there to offer customized solutions for your team – from mere day events to half or full board services with overnight stay. Depending on the character of your event you can choose from three conference offers. Our conference offers are valid as off 10 people. Naturally, we can produce an customized offers for events below 10 participants.

	Day Event	Half-Day package	24-Hour package
<b>„Ziegspitz“</b>	<ul style="list-style-type: none"> <li>• Conference room including standard equipment</li> <li>• Morning coffee break</li> <li>• Lunch buffet arranged by our chef</li> <li>• Afternoon coffee break</li> </ul>	<ul style="list-style-type: none"> <li>• Overnight Stays in a single room (queen-size bed) or double room with delicious breakfast buffet</li> <li>• Conference room including standard equipment</li> <li>• Morning coffee break</li> <li>• Lunch buffet arranged by our chef</li> <li>• Afternoon coffee break</li> </ul>	<ul style="list-style-type: none"> <li>• Overnight Stays in a single room (queen-size bed) or double room with delicious breakfast buffet</li> <li>• Conference room including standard equipment</li> <li>• Morning coffee break</li> <li>• Lunch buffet arranged by our chef</li> <li>• Afternoon coffee break</li> <li>• Evening buffet</li> </ul>
<b>„VDR“</b>	<ul style="list-style-type: none"> <li>• In addition 2 beverages during the meeting/conference (0.2 l each)</li> <li>• In addition 1 non-alcoholic beverage at lunch (0.5 l)</li> </ul>	<ul style="list-style-type: none"> <li>• In addition 2 beverages during the meeting/conference (0.2 l each)</li> <li>• In addition 1 non-alcoholic beverage at lunch (0.5 l)</li> </ul>	<ul style="list-style-type: none"> <li>• In addition 2 beverages during the meeting/conference (0.2 l each)</li> <li>• In addition 1 non-alcoholic beverage at lunch (0.5 l)</li> </ul>
<b>„Zugspitze“</b>	<ul style="list-style-type: none"> <li>• In addition unlimited beverages during the meeting/conference</li> <li>• In addition 1 non-alcoholic beverage at lunch (0.5 l)</li> </ul>	<ul style="list-style-type: none"> <li>• In addition unlimited beverages during the meeting/conference</li> <li>• In addition 1 non-alcoholic beverage at lunch (0.5 l)</li> </ul>	<ul style="list-style-type: none"> <li>• In addition unlimited beverages during the meeting/conference</li> <li>• In addition 1 non-alcoholic beverage at lunch (0.5 l) and with evening buffet</li> </ul>





## CONTACT DATA

Hotel am Badersee  
Am Badersee 1-5  
82491 Grainau / Zugspitzdorf

Tel.: +49 (0)8821 821 - 0  
Fax: +49 (0)8821 821 - 292  
E-mail: [info@hotelambadersee.de](mailto:info@hotelambadersee.de)  
Web: [www.hotelambadersee.de](http://www.hotelambadersee.de)

Our colleagues from the MICE Department can be contacted for your enquiry using the e-mail address: [mice@hotelambadersee.de](mailto:mice@hotelambadersee.de)

We guarantee you a reply within 24 hours.

## SOCIAL MEDIA

At the following addresses, you can also find us, follow our activities, and get informed:



Here we post things that are interesting, quirky, funny, suitable and informative. For example, here you can also find out about current offers in catering.

>> <http://www.facebook.com/HotelamBadersee>



You can also follow our posts on Instagram at any time. Simply subscribe to our channel at:

>> [https://www.instagram.com/hotel\\_am\\_badersee](https://www.instagram.com/hotel_am_badersee)



Auf unserem Blog informieren wir Sie über aktuelle Trends im Tagungsmarkt, Ideen für Ihr Rahmenprogramm sowie allgemeine Informationen zu Freizeitmöglichkeiten in und um Grainau.

>> <https://www.hotelambadersee.de/blog>



In order for us to continually improve, we need your help. Please rate us on Tripadvisor or Holidaycheck. Take a few minutes with your mouse and keyboard and you could already be benefiting from it on your next stay at the beautiful Badersee.



Here, from time to time you will also find little self-made films, links to films that we like or to informative clips about our beautiful Loisachtal. You will also find our official promotional videos here of course.

>> <http://www.youtube.com/user/HotelamBadersee>

Of course we are especially pleased to hear your praise, but also welcome your criticisms and suggestions. Obviously, you can also do this in a feedback conversation with our MICE Department or the management.

## ENVIRONMENTAL AWARENESS

Dear Guests,

our beautiful environment is being increasingly polluted by us, the people living on this planet. This is happening in many respects. It is true that as an individual there is not much one can do against this. But many individuals together make a multitude, which can also render a substantial contribution to a healthy environment.

Since October 2012, a gas-powered combined heat and power unit has been in operation in our cellar, not only supplying us with hot water and heat, but also with a large quantity of electricity. The small amount of electricity that we need to buy in is generated 100% from renewable energy sources. Of course, this also reduces our costs a little, but it also makes us a little less of a burden on the environment. In addition, in our renovation, we connected the exhaust ventilators in the lodge to a heat recovery system so that in winter we do not blow the hot air outside without it being used. Beyond this, during the renovation, we made sure that we use exclusively LEDs and lamps with low electricity consumption. All rooms have a master switch on the doors.

The breakfast buffet is kept free of sub-packaging, apart from a few necessary components. We take waste separation seriously, and superfluous consumers are switched off.

Please assist us in our efforts. This is simpler than you think. Separate the waste in your hotel room carefully. Try to use your hand towels and bath towels a second time before you give us the signal to change them by placing them in the bathtub or shower. Switch off superfluous consumers in your room if you do not need them. Do not leave the window open too long in winter. Brief inrush airing for a few minutes is much more effective and keeps more warmth in the building.

Here we live in one of the most beautiful spots in Germany, surrounded by stunning nature. Please help us to keep it like this for a long time.

Thank you very much.





## CANCELLATION CONDITIONS

### Cancellation conditions for events with up to 20 rooms

Free cancellation is possible up to 4 weeks before the start of the event.

Afterwards:

- Up to 3 weeks before arrival, 60% of the booked services are charged
- Afterwards, 90% of the booked services are charged

### Cancellation conditions for events up to 50 rooms

Free cancellation after booking is possible up to 8 weeks before the start of the event.

Afterwards:

- Up to 6 weeks before arrival, 30% of the booked services are charged
- Up to 4 weeks before arrival, 50% of the booked services are charged
- Afterwards, 90% of the booked services are charged

### Cancellation conditions for events with up to 100 rooms

Free cancellation after booking is possible up to 12 weeks before the start of the event.

Afterwards:

- Up to 8 weeks before arrival, 20% of the booked services are charged
- Up to 6 weeks before arrival, 30% of the booked services are charged
- Up to 4 weeks before arrival, 50% of the booked services are charged
- Afterwards, 90% of the booked services are charged

### Cancellation conditions for events with 100 rooms or above

Free cancellation is possible up to 14 weeks before the start of the event.

Afterwards:

- Up to 8 weeks before arrival, 20% of the booked services are charged
- Up to 6 weeks before arrival, 30% of the booked services are charged
- Up to 4 weeks before arrival, 50% of the booked services are charged
- Afterwards, 90% of the booked services are charged

**I Scope of Application**

1. These General Terms and Conditions shall apply to rental contracts for conference, banquet and function rooms of Hotel for banquets, seminars, meetings, expositions, presentations and other events and for any related services and supplies for Customer.
2. Hotel's prior written approval shall be required for sub-letting any rented rooms, invitations to interviews, selling or similar events; sec. 540 para. 1 sent. 2 BGB [German Civil Code] shall be waived, unless Customer is a consumer.
3. Customer's general terms and conditions shall only apply if this was previously expressly agreed upon in writing.
4. Any kind of publication referring to the venue must be timely submitted to Hotel for notification purposes; approval from Hotel shall be required.
5. Apart from that, additional conditions determined upon contract conclusion shall apply.

**II Contract Conclusion/Partner, Liability, Time Limit**

1. A contract shall be concluded once Hotel accepts Customer's application; those parties shall be Contractual Partners.
2. If the customer/applicant is not the event organiser and/or if the event organiser employs a commercial broker or organiser, the event organiser shall be jointly and severally liable together with Customer for any and all contractual duties to the extent that Hotel received a declaration from the event organiser in this regard.
3. Hotel shall be liable for their contractual duties with such level of care which prudent businesspersons would apply. Customer's claims for damages shall be excluded. However, this shall not apply to damage resulting from injuries to life, limb or health for which Hotel is responsible, other damage based on Hotel's intentional or grossly negligent violation of duties and any damage based on Hotel's intentional or negligent violation of typical contractual duties. The representatives' or vicarious agents' violations of duties shall be deemed Hotel's violations. Should Hotel's services be disrupted or defective, Hotel shall immediately remedy once they became aware of this or once Customer notified Hotel of any defects. Customer must take reasonable efforts to remove any disruptions or to keep any damage as small as possible. Apart from that, Customer must timely inform Hotel about the possible creation of extraordinarily large damage.
4. Any claims against Hotel shall generally become time-barred one year from the statutory period of limitation; claims for damages shall become time-barred after five years, regardless of knowledge. Abbreviated periods of limitation shall not apply to claims which are based on Hotel's intentional or grossly negligent violations of duties.
5. Customer must, without solicitation and not later than at contract commencement, inform Hotel about whether or not any events, for political, religious or other reasons, may pose a threat to smooth business operations, security or the reputation of Hotel.
6. Notifications, letters and deliveries for Customer shall be treated with care, whereby Hotel shall be in charge of delivery, storage and, upon request and against payment, forwarding.
7. If Customer is provided with a parking space at the hotel garage or car park, also for money, the vehicle shall not be considered to be stored by Hotel. Hotel is not obligated to surveillance and not liable for the theft of and damage to vehicles parked on the hotel property or for their contents.

**III Services, Prices, Payments, Offsets**

1. Hotel must render any services ordered by Customer and promised by Hotel.
2. Customer has no claim for the provision of certain rooms. If they were promised certain rooms under an order confirmation and/or a hotel accommodation contract which then turn out not to be available, Hotel is obligated to provide for equivalent replacement at their hotel or at other, comparable buildings.
3. The breakfast lump sum indicated on the accommodation invoice includes, in addition to breakfast, pro rata shares in the below services which hotel guests are able to use without additional payments: sauna and fitness room usage, car park usage (except for the underground car park), E-car loading station usage on the hotel property and hotel Wi-Fi usage. These charges will also apply if hotel guests do not use these services for any reasons whatsoever
4. Hotel may subject their approval of a subsequent reduction of rented rooms, Hotel services or the accommodation period for guests requested by them to price increases for rooms and/or any other Hotel services. Hotel's invoices not showing a due date must be paid within ten days from receipt with no deductions. Hotel may request Customer to immediately pay any outstanding amounts. Should Customer be in arrears, Hotel may request statutory default interest. Hotel may produce evidence showing more extensive damage. Collection-related costs must be borne by Customer.
6. Upon contract conclusion, Hotel may request from Customer reasonable advance payments or collaterals in the form of credit card guarantees or similar. The amount of such advance payments and the due dates may be contractually agreed upon in writing. Contractual advance payments can not be reimbursed. Should Hotel, in the case of cancellation, be able to rent their bedrooms and function rooms at the same price, any advance payments shall be refunded. If the bedrooms and function rooms can not be sold at the same price, Customer must pay the difference.
7. In justified cases, e.g. Customer's arrears or extensions of the contractual scope, Hotel may request advance payments or collaterals in terms of para. 4 above or an increase in contractual advance payments or collaterals until complete payment, even after contract conclusion and prior to event beginning.
8. Customer may only offset their undisputed or legally determined claims against any claims from Hotel, reduce them this way and/or exercise a right of retention.
9. If Hotel, after contract conclusion, becomes aware of circumstances which, according to Hotel, interfere with Customer's credit standing, Hotel may cancel the contract or provide any services only against advance payments or collaterals.

**IV Withdrawal by Customer (Cancellation/Reversal)**

1. Hotel's written approval shall be required for Customer's withdrawal from any contract concluded with Hotel. If not so, Customer must in each case pay the contractual room rent and services provided by third parties if Customer fails to use any contractual services and if subletting is impossible. This shall not apply to Hotel's violations of duties concerning Customer's legally protected rights, goods and interests if Customer can not be expected to continue such contract or if they are entitled to any other statutory or contractual right to withdrawal.
2. If Hotel and Customer agreed upon a date for free-of-charge withdrawal in writing, Customer may withdraw by that date, without this leading to payments to or damages claims for Hotel. Customer's right to withdrawal shall cease to exist if they failed to exercise this right towards Hotel in writing by the day agreed upon, unless Customer withdraws in terms of sec. IV para. 1 sent. 3.
3. Should Customer withdraw after contract conclusion and/or the contractual free-of-charge withdrawal period, Hotel may, in addition to contractual room rents and third-party services costs, charge up to 90% of the loss of earnings from meals.
4. Calculation of earnings from meals shall be based on the following: menu/buffet prices plus drinks x number of participants. If the menu price still had to be agreed, the regular half-board buffet/menu is taken as a basis. Drinks shall be charged at one third of the menu price.
5. Should the Parties agree upon meeting lump sums per participant, Hotel may, if Customer withdraws after contract conclusion and/or the end of the free-of-charge withdrawal period, charge up to 90% of the meeting lump sum multiplied by the number of participants.
6. A deduction of saved expenses is considered under para. 3 through 5. Customer may produce evidence showing that the above claim exists not at all or that it is smaller than the requested amount.

**V Withdrawal by Hotel**

1. If the Parties agreed in writing that Customer may withdraw from a contract on a free-of-charge basis during a given period of time, Hotel may withdraw from a contract during that period if they receive enquiries from other customers for the contractual function rooms and if Customer, after Hotel's query, does not waive their right to withdrawal.
2. If Customer fails to make any contractual advance payments or to provide collaterals requested in terms of sec. III para. 5 and/or 5 after a grace period granted by Hotel, Hotel shall also be entitled to withdraw from the contract.
3. Also, Hotel may extraordinarily cancel the contract for factually justified reasons, such as if
  - force majeure or any other reasons beyond Hotel's control make contract fulfillment impossible;
  - events were booked by indicating misleading or wrong facts, including, without limitation, those concerning Customer or the reason for their stay;
  - there is justified reason for Hotel to believe that any events pose a threat to smooth business operations, security or Hotel's reputation without Hotel having any influence on this, or
  - a violation of sec. I para. 2 above exists.
4. In the event of Hotel's justified withdrawal, Customer shall have no claim for damages. Should Hotel have any claims for damages against Customer due to withdrawal in terms of para. 2 or 3 above, Hotel may request a lump sum in this regard; sec. IV para. 3 through 6 shall apply accordingly.
5. Hotel may also withdraw if they become aware of circumstances according to which the contractual partner's financial situation considerably deteriorated, in particular if Customer fails to pay outstanding claims to Hotel or to provide sufficient collaterals with the effect of Hotel's claims for payment being at risk. This shall particularly apply if:
  - the Customer applied for insolvency proceedings, instituted extra-judicial debt settlement proceedings or suspended their payments; or
  - insolvency proceedings are instituted or rejected due to a lack of funds or any other reasons.

**VI Changes of the Number of Participants/Event Times**

1. Changes of the number of participants by more than 5% must be communicated to Hotel not later than 10 working days prior to the event; Hotel's written approval shall be required. Any additional deviations shall be charged to Customer.
2. Reductions of the number of participants by Customer by 10% at the most communicated to Hotel not later than 10 working days prior to the event shall be accepted by Hotel for invoicing purposes. In the case of additional deviations, the original contractual number of participants minus 5% shall be taken as a basis. Customer shall have the right, subject to evidence production, to reduce the contractual price by any expenses saved due to smaller numbers of participants. In this regard, Customer's savings due to the 5% tolerance must be considered.
3. In the event of upward deviations, the actual number of participants shall be charged. Should the number of participants be exceeded by more than 5%, it is possible that the requested meal order can not be served, unless Hotel agreed to these changes.
4. If the number of participants deviates by more than 10%, Hotel shall be entitled to newly establish contract prices and to change room confirmations, unless this is unreasonable for Customer.
5. Should the contractual event beginning and end be changed and should Hotel agree to this, Hotel may charge these additional service times, unless Hotel is responsible for this. In the case where the end of the event is postponed and where Hotel must accommodate any guests in other hotels due to such postponement, Customer shall bear any related costs; additional claims for damages for Hotel shall not be affected by this.
6. For events ending later than 11.00 p.m., Hotel may, if not agreed otherwise, charge the relevant costs based on separate receipts. Also, Hotel may charge any travel expenses for employees based on separate receipts if they incur additional costs for travelling home after the end of the event.

**VII Bringing Food and Beverages**

1. Customer shall generally be prohibited from bringing their own food and beverages at events. Exceptions require a written agreement with Hotel in which case an amount for covering overheads shall be calculated. In the event of violations, Hotel may request lump-sum compensation for each participant covering the relevant loss of earnings which Hotel would have generated by rendering this service. Hotel shall not be liable for any health damage resulting from food or beverages which guests brought along.

**VIII Technical Equipment and Connections**

1. To the extent that Hotel procures technical equipment on behalf of Customer's request, they shall act in the name, on account and as a representative of Customer. Customer shall be liable for careful handling and return in an ordinary state; they shall hold Hotel harmless against third-party claims from providing this equipment.
2. The employment of Customer's own electric systems by using Hotel's mains shall require Hotel's approval. Any costs for disruptions of or damage to Hotel's technical equipment caused by such usage shall be borne by Customer, unless Hotel is responsible for this. If applicable, Hotel may calculate and charge electricity costs resulting from the above usage.
3. Upon Hotel's approval, Customer may use their own telephone, fax and data transfer equipment. Hotel may charge connection fees for this.
4. If usage of Customer's own equipment results in Hotel's equipment not being used, they may charge a compensation fee.
5. Disruptions with technical or other equipment provided by Hotel shall be immediately removed, if possible. Payment may not be suspended or reduced to the extent that such disruptions are beyond Hotel's control.
6. Authority licences required for the event, conditions and approvals must be obtained by Customer at their own cost on time. They shall also be liable for complying with public-law instructions and other regulations, noise protection provisions and youth protection provisions, such as GEMA fee payments.

**IX Hotel's Liability**

1. Exposition or other, personal items brought along shall be at the venue and/or the hotel building at Customer's own risk. Hotel shall not be liable for any losses, damage or any other property damage, except for cases of gross negligence or intention of Hotel. However, this shall not apply to damage resulting from injuries to life, limb or health. Additionally, all cases where storage, due to the individual circumstances, represents a contractual duty shall also be excluded from liability indemnification. Apart from the cases under sent. 4, storage contracts require express agreements.
2. Decoration materials brought along must fulfil fire protection requirements and Hotel may request the production of official evidence. If no evidence is produced, Hotel may remove any materials which had already been installed at Customer's expense. Considering possible damage, the establishment and fixing of items must be agreed upon with Hotel first.
3. Exposition and other items brought along must be removed immediately at the end of the event. If Customer fails to do so, Hotel may remove and store the materials at Customer's expense. Should any items remain at the venue, Hotel may charge reasonable compensation for the usage term. Customer may produce evidence showing that the above claim exists not at all or that it is smaller than the requested amount.
4. Other remaining items from event participants shall only be forwarded upon the relevant participant's request, at their risk and their expense. Hotel shall store the items for three months; after that, they shall be handed over to the local lost-and-found office if they clearly have a value. Storage costs must be borne by Customer. Unless the items have a clear value, Hotel reserves the right, at the end of the term, to destroy them at Customer's expense.
5. Hotel's liability towards Customer for items brought along shall be, in terms of the German Civil Code (sec. 702), limited to EUR 3,500.00. Liability shall be excluded if bedrooms, meeting rooms and containers in which guests store their items remain unlocked. In terms of the BGB, liability for storage of money and goods of value in the hotel safe shall be limited to the amount of EUR 800.00; apart from that, sec. 701 et seq. BGB shall particularly apply.
6. Customer must dispose of any packaging materials supplied by them or third parties for the event prior to or after the event. Should Customer leave any packaging materials at the hotel, Hotel may dispose them at Customer's expense.

**X Customer's Liability for Damage**

1. If Customer is an entrepreneur, they shall be liable for building and equipment damage caused by event participants and/or visitors, employees, other third parties related to them or by themselves.
2. Hotel may request Customer to provide reasonable collaterals (such as insurances, deposits and suretyships).

**XI Final Provisions**

1. Event contract, order acceptance or General Terms and Conditions amendments and supplements must be made in writing; unilateral amendments and supplements by Customer shall be invalid.
2. The place of payments and fulfilment shall be Hotel's registered office.
3. The exclusive venue, also for cheque and draft disputes, shall be Hotel's commercial-law registered office for transactions. If any contractual partner fulfils the requirements under sec. 38 para. 2 ZPO [German Code of Civil Procedure] and has no venue in Germany, Hotel's commercial-law registered office shall be the venue.
4. German law shall apply; CISG provisions and conflict of laws shall be excluded.
5. Should individual provisions under these General Terms and Conditions for the Hotel Accommodation Contract be ineffective or invalid, this shall not affect validity of the remaining provisions; apart from that, statutory provisions shall apply.

**I Scope of Application**

- These General Terms and Conditions shall apply to rental contracts for hotel rooms for accommodation purposes and related services supplies to Customer ("Hotel Accommodation Contract"). "Hotel Accommodation Contract" shall include and replace the below terms: lodging, guest accommodation, hotel and hotel room contract.
- Hotel's prior written approval shall be required for sub-letting any rented rooms, for the usage for purposes other than lodging, public invitations or other advertisement purposes, job interviews, selling or similar events and for the usage of the hotel property outside rented rooms and this may also be subject to the payment of additional remuneration; sec. 540 para. 1 sent. 2 BGB [German Civil Code] shall be waived, unless Customer is a consumer.
- Customer's general terms and conditions shall only apply if this was previously expressly agreed upon in writing.
- Apart from that, additional conditions determined upon contract conclusion shall apply.

**II Contract Conclusion/Partner, Time Limit**

- A contract shall be concluded once Hotel accepts Customer's application. Hotel shall have a right to confirm room bookings in writing.
- Hotel and Customer shall be Contractual Partners. If third parties placed an order on behalf of Customer, they shall be jointly and severally liable to Hotel for any duties under the Hotel Accommodation Contract to the extent that Hotel received a related declaration from the third party.
- Any claims against Hotel shall generally become time-barred one year from the statutory period of limitation; claims for damages shall become time-barred after five years, regardless of knowledge. Abbreviated periods of limitation shall not apply to claims which are based on Hotel's intentional or grossly negligent violations of duties.

**III Services, Prices, Payments, Offsets**

- Hotel must have the rooms ready which Customer booked and render any services ordered by them.
- The breakfast lump sum indicated on the accommodation invoice includes, in addition to breakfast, pro rata shares in the below services which hotel guests are able to use without additional payments: sauna and fitness room usage, car park usage (except for the underground car park), E-car loading station usage on the hotel property and hotel Wi-Fi usage. These charges will also apply if hotel guests do not use these services for any reasons whatsoever.
- Pets may be brought to the hotel only if this was agreed and a charge must be paid (one dog per room).
- Customer shall be obligated to pay Hotel's contractual and/or applicable prices for room provisions and any other services; this shall also apply to any Hotel services and expenses to third parties if these were requested by Customer. Contractual prices shall include applicable value-added tax. Should the value-added tax rate increase on the day of service provision, the contractual prices shall be adjusted accordingly and Hotel may charge the relevant value-added tax increase.
- Hotel may also change prices if Customer subsequently requests changes to the number of room bookings, Hotel services or the time of accommodation for guests and if Hotel agrees to this.
- Hotel invoices not showing a due date must be paid 14 days from receipt with no deductions. Hotel may request Customer to immediately pay outstanding invoices at any time. Should Customer be in arrears, Hotel may request statutory default interest currently amounting to 8% and/or, in the case of legal transactions in which consumers are involved, to the amount of 5% above the base lending rate; any other collection process costs shall be borne by Customer.
- Upon contract conclusion, Hotel may request from Customer reasonable advance payments or collaterals in the form of credit card guarantees or similar. The amount of such advance payments and the due dates may be contractually agreed upon in writing; In the event of advance payments or collaterals for package holiday, statutory provisions shall not be affected.
- In justified cases, e.g. Customer's arrears, Hotel may request advance payments or collaterals in terms of para. 7 above or an increase in contractual advance payments or collaterals until complete payment, even after contract conclusion and prior to the beginning of the stay.
- Also, Hotel shall be entitled, at the beginning of and during Customer's stay, to request reasonable advance payments or collaterals in terms of para. 7 above for existing or future contractual claims, unless these have already been made or provided in terms of para. 7 and/or para. 8 above.
- Customer may only offset their undisputed or legally determined claims against any claims from Hotel, reduce them this way and/or exercise a right of retention.

**IV Withdrawal by Customer (Cancellation/Reversal) and/or Non-Usage of Hotel Services (No-Show)**

- Hotel's written approval shall be required for Customer's withdrawal from any contract concluded with Hotel. If not so, Customer must pay the contractual price also if Customer fails to use any contractual services. This shall not apply to Hotel's violations of duties concerning Customer's legally protected rights, goods and interests if Customer, for this reason, can not be expected to continue such contract or if they are entitled to any other statutory or contractual right to withdrawal.

- If Hotel and Customer agreed upon a date for free-of-charge withdrawal in writing, Customer may withdraw by that date, without this leading to payments to or damages claims for Hotel. Customer's right to withdrawal shall cease to exist if they failed to exercise this right towards Hotel in writing by the day agreed upon, unless Customer withdraws in terms of sec. IV para. 1 sent. 3.
- If a right to withdrawal was not agreed or if this has already ceased to exist, there is no statutory right to withdrawal or cancellation, either. Hotel shall be entitled to request lump-sum compensation from Customer for any damage incurred by them. In this case, Customer shall be obligated to pay at least 90% of the contractual price for stays with or without breakfast, 70% of half-board arrangements and 60% for full-board arrangements. Customer may produce evidence showing that the above claim exists not at all or that it is smaller than the requested amount.
- Should Hotel calculate the exact amount of damage, compensation shall be limited to the contractual price for services to be rendered by Hotel, reduced by the value of expenses saved by Hotel and by what Hotel earns by using the Hotel services in any other manner.
- The above compensation regulations shall apply accordingly if a guest does not use the booked room or service without communicating this on time (no-show).
- The period for free-of-charge hotel room cancellation shall depend on the number of rooms booked.
  - Group bookings: depending on the group size, free-of-charge cancellation shall be possible not later than 14 weeks prior to arrival; the group contract cancellation conditions shall apply.
  - Arrangements: free-of-charge cancellation until five days prior to arrival. Since this is a lump sum, bad-weather price reductions or reimbursements are not possible. We recommend to purchase travel cancellation expenses insurance.
  - Individual bookings: Low season: free-of-charge cancellation up to 24 hours prior to arrival. High season (public holidays such as Christmas, New Year's Eve): free-of-charge cancellation up to 14 days prior to cancellation.

**V Withdrawal by Hotel**

- If the Parties agreed in writing that Customer may withdraw from a contract on a free-of-charge basis during a given period of time, Hotel may withdraw from a contract during that period if they receive enquiries from other customers for the contractual bedrooms and if Customer, after Hotel's query, does not waive their right to withdrawal. This shall accordingly apply to granting options if Hotel received other enquiries and if Customer, after Hotel's query, fails to make a firm booking during the time period indicated by Hotel. In this case, firm booking shall mean that a hotel accommodation contract is concluded on that day and that the period for free-of-charge withdrawals originally agreed upon is suspended.
  - If Customer fails to make any contractual advance payments or to provide collaterals requested in terms of sec. III para. 7 and/or 8 after a grace period granted by Hotel, Hotel shall also be entitled to withdraw from the contract.
  - Also, Hotel may extraordinarily cancel the contract for factually justified reasons, such as if
    - force majeure or any other reasons beyond Hotel's control make contract fulfillment impossible;
    - bedrooms were booked by indicating misleading or wrong facts, including, without limitation, those concerning Customer or the reason for their stay;
    - there is justified reason for Hotel to believe that the usage of any Hotel services poses a threat to smooth business operations, security or Hotel's reputation without Hotel having any influence on this;
    - a violation of sec. I para. 2 above exists.
- In the event of Hotel's justified withdrawal, Customer shall have no claim for damages.
- Hotel may prevent and/or request any and all job interviews, selling or other events which had not been approved to be immediately terminated.
- Should Hotel have any claims for damages against Customer due to withdrawal in terms of para. 2, 3 and 5 above, Hotel may request a lump sum in this regard; sec. IV para. 3 shall apply accordingly. In these cases, Customer still has the right to show that no damage occurred or that only minor damage occurred.

**VI Room Booking, Provision and Return**

- Customer does not acquire a claim for the provision of certain rooms. If they were promised certain rooms under an order confirmation and/or a hotel accommodation contract which then turn out not to be available, Hotel is obligated to provide for equivalent replacement at their hotel or at other, comparable buildings.
- Booked rooms shall be available to Customer from 3.00 p.m. on the agreed day of arrival. Customer has no claim for earlier provision. Unless later times of arrival were expressly agreed or unless advance payments were made for the relevant room, Hotel shall be entitled to sell booked rooms to other customers after 6.00 p.m., without Customer having a right to deduct any claims against Hotel from this. Hotel's claims under sec. IV shall not be affected by this.
- On the agreed day of departure, the rooms must be vacated by 11.00 a.m. at the latest. After that, Hotel may request 50% of the complete accommodation price for lately vacating the room until 6.00 p.m. in contrast to the contract; after 6.00 p.m., it may request 100% of the price.
- This shall not establish any contractual claims for Customer. They shall be entitled to show that Hotel suffered no loss of earnings at all or that the loss was smaller.

**VII Hotel's Liability**

- Hotel shall be liable for their contractual duties with such level of care which prudent businesspersons would apply. Customer's claims for damages shall be excluded. This shall not include any damage resulting from violations of life, limb or health for which Hotel is responsible, other damage based on Hotel's intentional or grossly negligent violation of duties and any damage based on Hotel's intentional or negligent violation of typical contractual duties. The representatives' or vicarious agents' violations of duties shall be deemed Hotel's violations. Should Hotel's services be disrupted or defective, Hotel shall immediately remedy once they became aware of this or once Customer notified Hotel of any defects. Customer must take reasonable efforts to remove any disruptions or to keep any damage as small as possible.
- For items brought along by Customer, Hotel shall be liable according to statutory provisions, that is, to the maximum amount of a hundredfold of the room price and not more than EUR 3,500.00 for money, securities and other treasures with a value of up to EUR 800.00. Money, securities and treasures may, up to a maximum value, be stored in the hotel or room safe according to the sums insured of the relevant hotel. Hotel recommends to use this possibility. Liability claims shall cease to exist, unless Customer, after becoming aware of loss, destruction or damage, fails to immediately notify Hotel (sec. 703 BGB). Liability shall only exist in cases where rooms and containers in which the items had been stored were locked.
- If Customer is provided with a parking space at the hotel garage or car park, also for money, this shall not be considered the conclusion of a storage contract. Hotel shall not be liable for the theft of and damage to vehicles parked on the hotel property or for their contents, except for cases of intention and gross negligence; para. 1 sent. 2 through 4 above shall apply accordingly.
- A wake-up request will be performed with utmost care.
- Hotel does not assume any liability. Notifications, letters and deliveries for guests shall be treated with care, whereby Hotel shall be in charge of delivery, storage and, upon request and against payment, forwarding. Para. 1 sent. 2 through 4 above shall apply accordingly.
- Customer's items left at the hotel shall be forwarded only upon their request and at their expense and risk. Hotel shall store the items for three months. After that, they will be taken to the local lost-and-found office if they clearly have a value. Unless the items have a clear value, Hotel reserves the right, at the end of the term, to destroy them.

**VIII Final Provisions**

- Hotel accommodation contract, order acceptance or General Terms and Conditions amendments and supplements must be made in writing; unilateral amendments and supplements by Customer shall be invalid.
- The place of payments and fulfilment shall be Hotel's registered office.
- The exclusive venue, also for cheque and draft disputes, shall be Hotel's commercial-law registered office for transactions. If any contractual partner fulfils the requirements under sec. 38 para. 2 ZPO and has no venue in Germany, Hotel's commercial-law registered office shall be the venue.
- German law shall apply; CISG provisions and conflict of laws shall be excluded.
- Should individual provisions under these General Terms and Conditions for the Hotel Accommodation Contract be ineffective or invalid, this shall not affect validity of the remaining provisions; apart from that, statutory provisions shall apply. The Parties undertake to replace any invalid provisions by such valid provisions which comes closest to the sense of the invalid ones and which is legally effective.



## HOTEL AM BADERSEE

ZUGSPITZDORF GRAINAU

Am Badersee 1-5 | D-82491 Grainau

Reservation & Information

Tel. +49 (0)8821 821-0 | Fax +49 (0)8821 821-292

[info@hotelambadersee.de](mailto:info@hotelambadersee.de) | [www.hotelambadersee.de](http://www.hotelambadersee.de)